

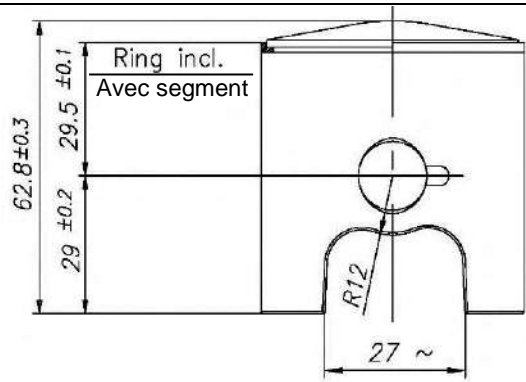
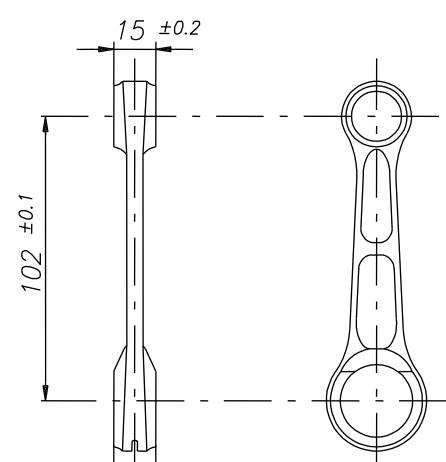
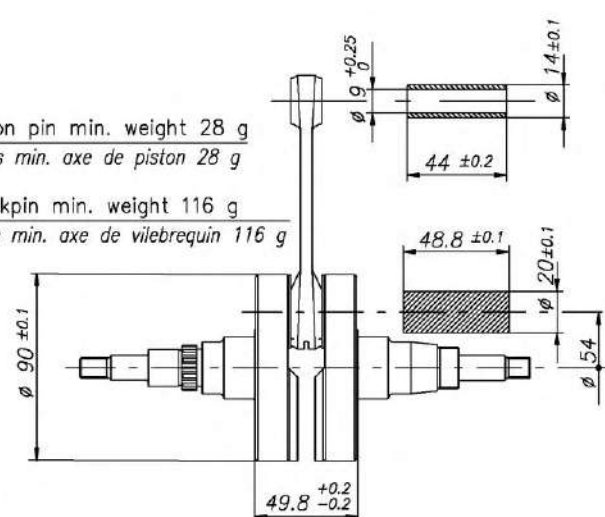
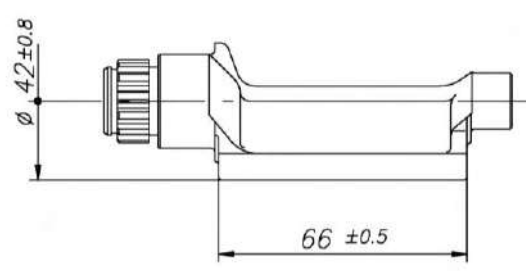

125cc RL-C TaG

		FEATURES - CARACTERISTIQUES	
		Cylinder volume <i>Volume du cylindre</i>	123.67 cm ³
		Bore <i>Alésage</i>	54 mm
		Max. theoretical bore <i>Alésage théorique max.</i>	54.28 mm
		Stroke <i>Course</i>	54 mm
		Cooling system <i>Système de refroidissement</i>	Water <i>Eau</i>
		Inlet system <i>Système d'admission</i>	Reed valve <i>À clapets</i>
Carburetor <i>Carburateur</i>	Tryton Hobby 27/C	Cylinder / crankcase transfers n° <i>N° de canaux cylindre / carter</i>	3
Number of piston rings <i>Nombre de segments</i>	1	Inlet / exhaust ports number <i>N° lumières admiss. / échapp.</i>	3
Big end conr. ball-bearing diam. <i>Diamètre palier tête de bielle</i>	20x26x15	Combustion chamber shape <i>Forme chambre de combustion</i>	Spherical <i>Sphérique</i>
Crankshaft ball-bearing diam. <i>Diamètre palier du vilebrequin</i>	30x62x16	Selettra or PVL ignition <i>Allumage Selettra ou PVL</i>	Digital
Small end conr. ball-bearing diam. <i>Diamètre palier pied de bielle</i>	14x18x17.5	RPM limiter <i>Limiteur de tours</i>	Yes <i>Oui</i>
Distance between conrod centers <i>Longueur (entre axe) de la bielle</i>	102 mm	Generator for battery charging <i>Générateur de recharge batterie</i>	Yes <i>Oui</i>
Balancing shaft <i>Arbre d'équilibrage de vilebr.</i>	Yes <i>Oui</i>	Electric starter <i>Démarrateur électrique</i>	Yes <i>Oui</i>

DESCRIPTION OF THE MATERIAL DESCRIPTION DES MATERIAUX		PISTON
Conrod material <i>Matériel de la bielle</i>	Steel <i>Acier</i>	 <p>Piston min. weight (ring incl.) 128 g <i>Poids min. piston (avec segment) 128g</i></p>
Crankshaft material <i>Matériel du vilebrequin</i>	Steel <i>Acier</i>	
Balancing shaft material <i>Matériel de l'arbre d'équilibrage</i>	Steel <i>Acier</i>	
Gears material <i>Matériel des engrenages</i>	Steel <i>Acier</i>	
Starter ring material <i>Matériel de la couronne démarr.</i>	Steel <i>Acier</i>	
Head material <i>Matériel de la culasse</i>	Aluminium	
Cylinder material <i>Matériel du cylindre</i>	Aluminium	 <p>Min. weight 110 g <i>Poids min. 110 g</i></p>
Liner material <i>Matériel de la chemise</i>	Iron <i>Fonte</i>	
Crankcase material <i>Matériel du carter</i>	Aluminium	
Piston material <i>Matériel du piston</i>	Aluminium	
Piston rings material <i>Matériel des segments</i>	Iron <i>Fonte</i>	
Exhaust muffler material <i>Matériel du pot d'échappement</i>	Sheet-steel <i>Tôle acier</i>	
Ball-bearings <i>Roulements</i>	6206 type	
CRANKSHAFT - VILEBREQUIN		
 <p>Piston pin min. weight 28 g <i>Poids min. axe de piston 28 g</i></p> <p>Crankpin min. weight 116 g <i>Poids min. axe de vilebrequin 116 g</i></p> <p>Complete crankshaft min. weight 2150 g <i>Poids min. du vilebrequin complet 2150 g</i></p>		 <p>Min. weight 315 g <i>Poids Min. 315 g</i></p>

CYLINDER DEVELOPMENT - DEVELOPPEMENT DU CYLINDRE

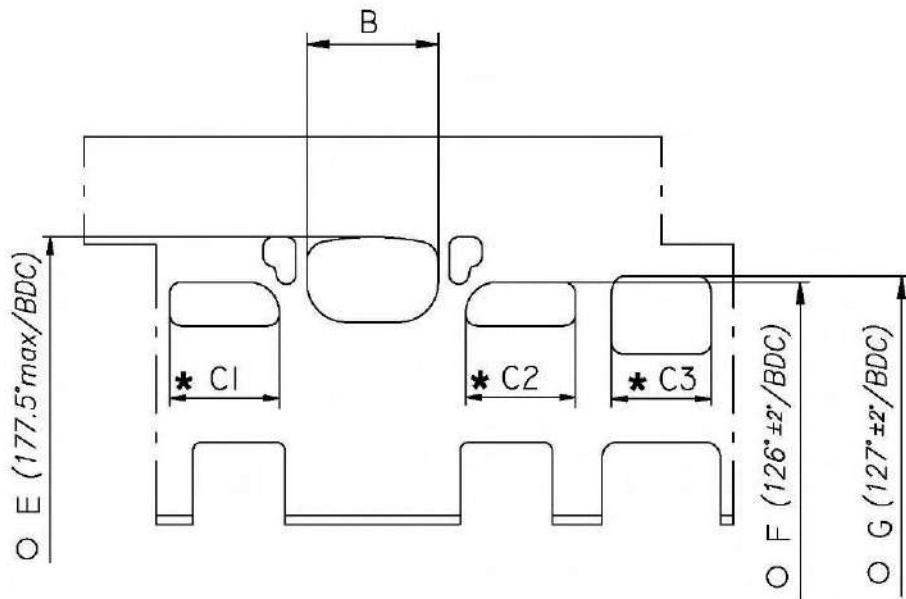

B	≤ 36.5 mm
C1 = C2	≤ 30 mm
C3	≤ 28.5 mm
E	177.5° max
F	126° ± 2°
G	127° ± 2°

* **CHORDAL READING**
LECTURE CORDALE

○ **ANGULAR READING BY INSERTING A 0.2x5 mm GAUGE**
LECTURE ANGULAIRE PAR INSERTION D'UNE CALE DE 0.2x5 mm

CYLINDER BASE VIEW
VUE DE LA BASE DU CYLINDRE

CYLINDER CROSS SECTION VIEW
VUE EN SECTION DU CYLINDRE

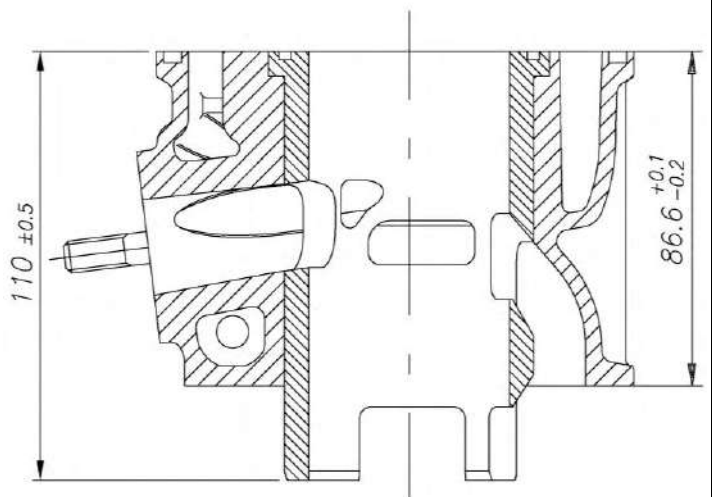
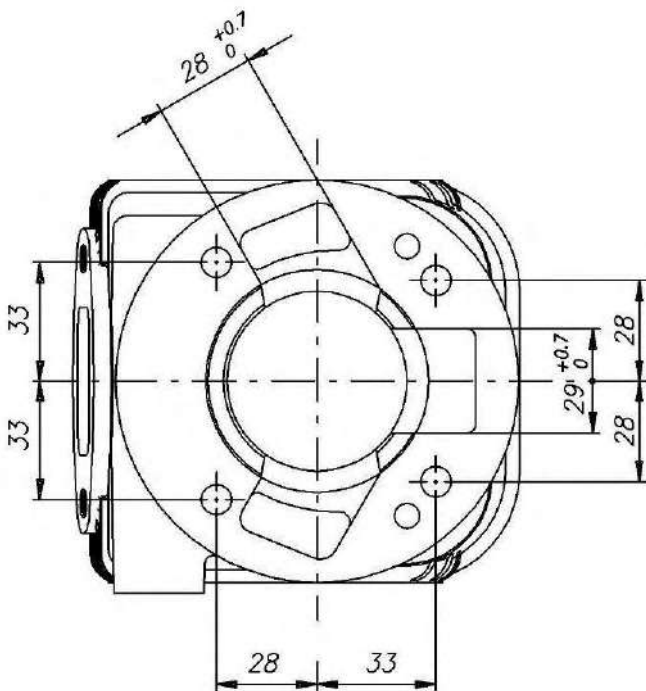

COMBUSTION CHAMBER VIEW
VUE DE LA CHAMBRE DE COMPRESSION

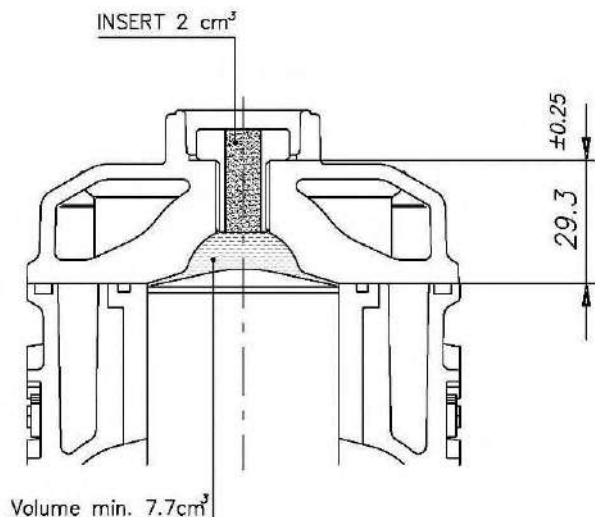

COMBUSTION CHAMBER VOLUME TOT. = 9.7 cm³ min.
VOLUME CHAMBRE COMBUSTION TOT. = 9.7 cm³ min.

ATT.: SQUISH MIN. = 0.90 mm
 (measured with Ø1.5mm TIN - mesurée avec de l'étain Ø1.5mm)

CRANKCASE INSIDE VIEW
VUE A' L' INTERIEUR DU CARTER

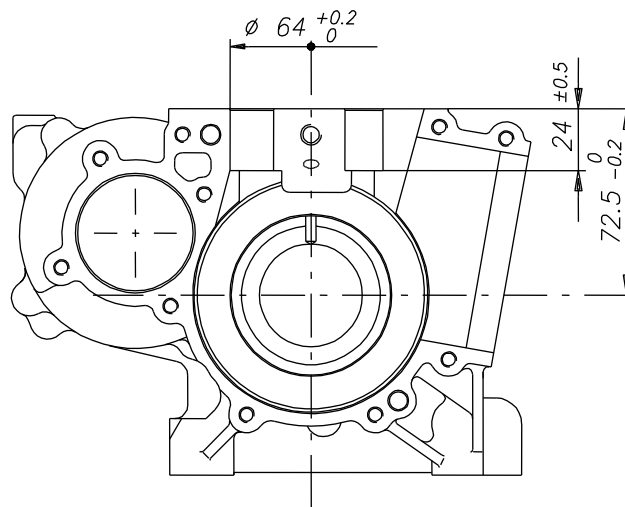

VENTURI CARB. DIMENSIONS
DIMENSIONS DU VENTURI DU CARBURATEUR

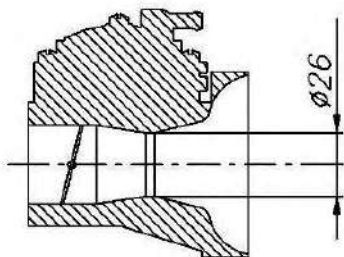

INLET CONVEYOR DIMENSIONS
CONVOYEUR D'ADMISSION

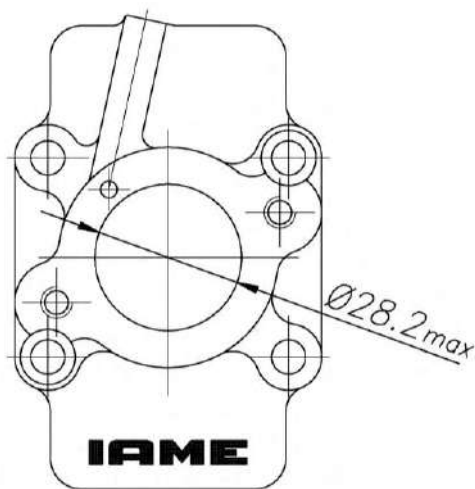

INLET SILENCER
SILENCIEUX D'ASPIRATION

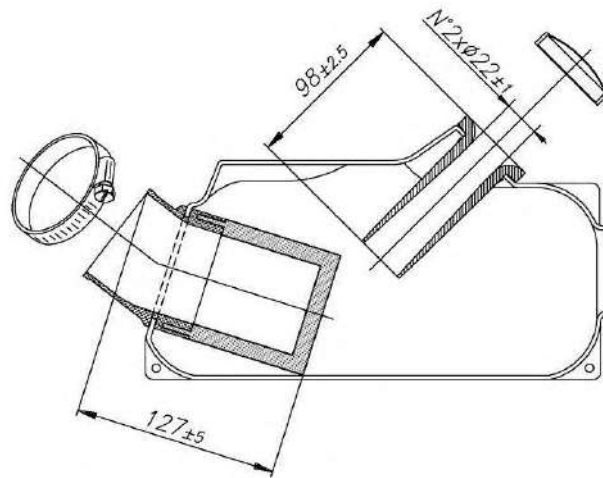

REEDS DIMENSIONS / CLAPETS

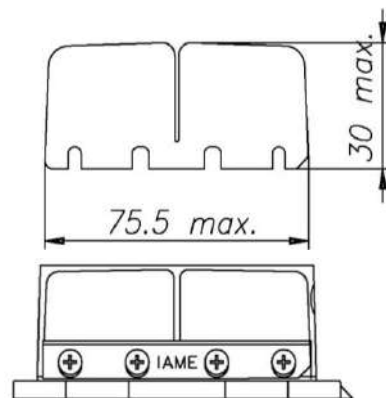

DESCRIPTION OF THE CLUTCH - DESCRIPTION DE L' EMBRAYAGE

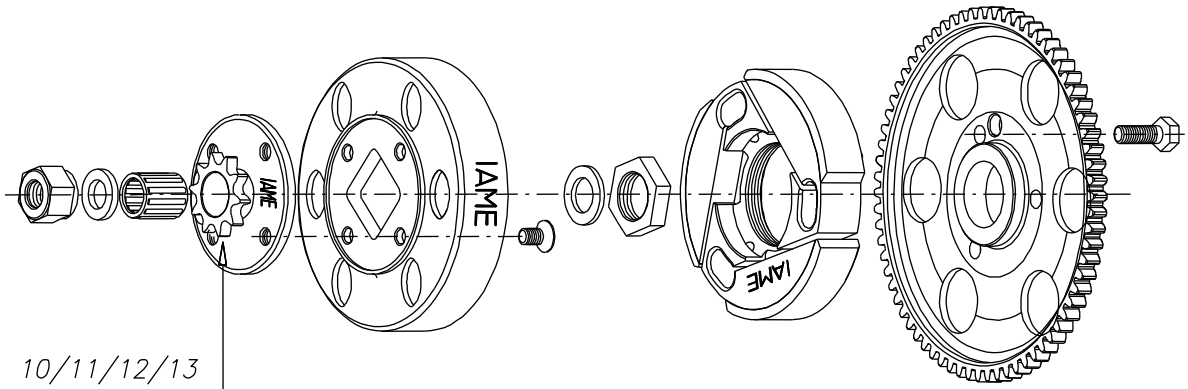

Z= 10/11/12/13

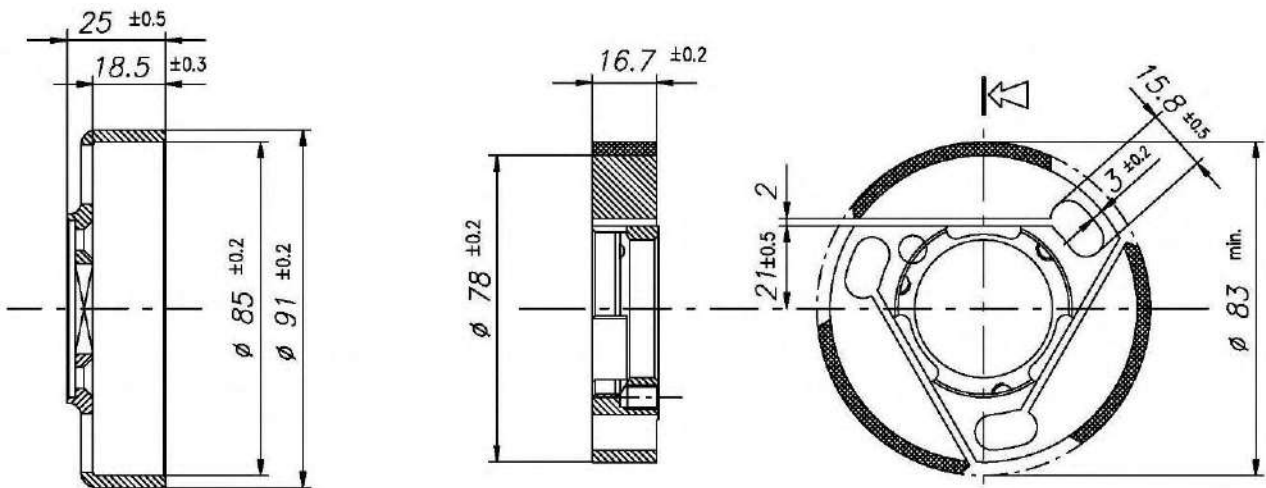

Min. weight 225 g
Poids min. 225 g

Min. weight 360 g
Poids min. 360 g

EXHAUST MUFFLER VIEW AND DIMENSIONS VUE ET DIMENSIONS DU SILENCIEUX D' ECHAPPEMENT

N° 8 ROWS OF HOLES. THE ROWS ARE COMPOSED OF N°8 HOLES, FOR A TOT OF 64 HOLES. THE HOLES HAVE A TOLLERANCE OF ±0.2
N° 8 RANGEES DE TROUS. LES RANGEES SE COMPOSENT DE N°8 TROUS, POUR UN TOTAL DE 64 TROUS. LES TROUS ONT UNE TOLERANCE DE ±0.2

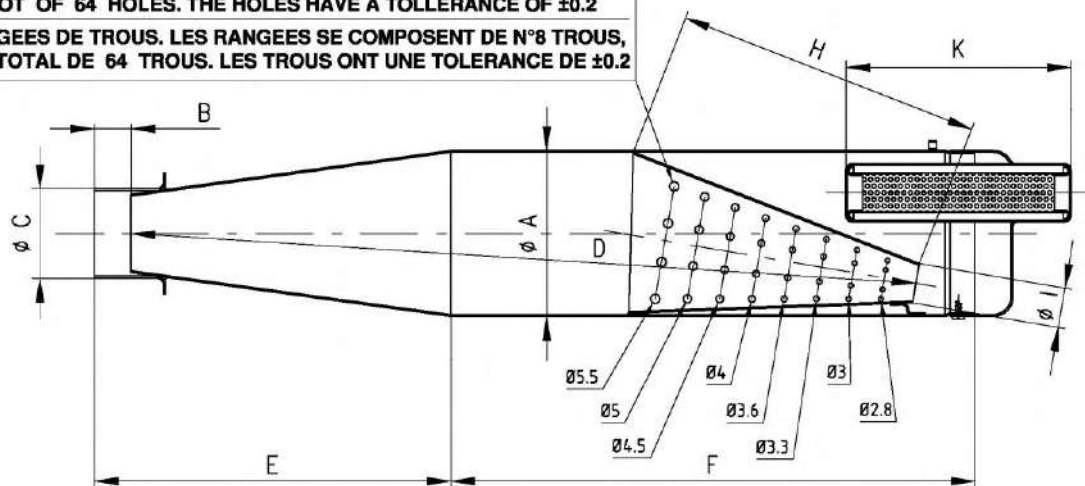

A: $100 \pm 1 \text{ } \phi_{\text{ext.}}$	D: 485 ± 5	H: 180 ± 5
B: 22 ± 1	E: 218 ± 5	l: $24 \pm 2 \text{ } \phi_{\text{ext.}}$
C: $54 \pm 1 \text{ } \phi_{\text{ext.}}$	F: 315 ± 3	K: 130 ± 3

Min. weight 1.39 Kg
Poids min. 1.39 Kg

WIRING DIAGRAM (SELETTRA DIGITAL "K" IGNITION)
 SCHEMA CIRCUIT ELECTRIQUE (ALLUMAGE SELETTRA DIGITAL "K")

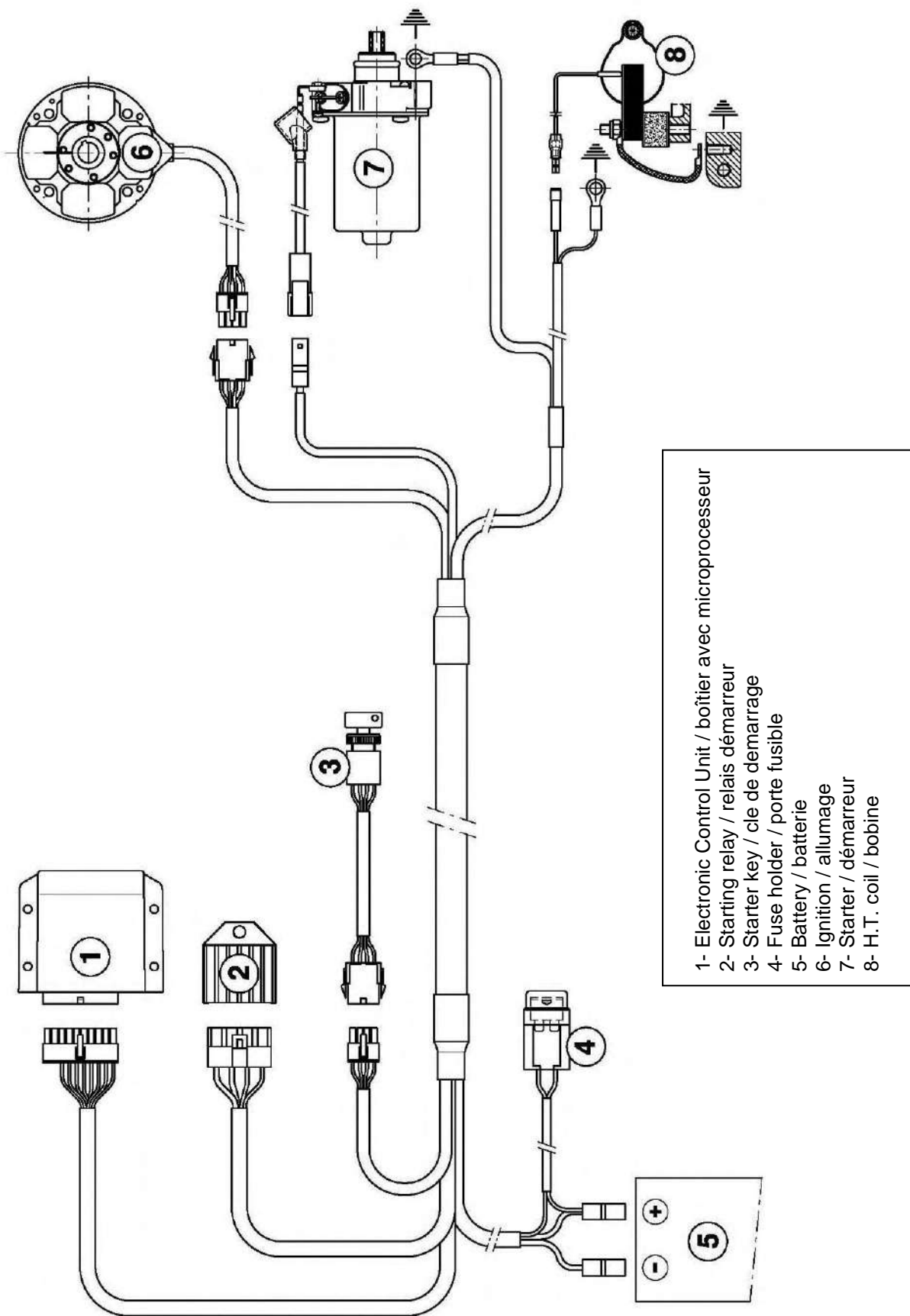

- 1- Electronic Control Unit / boîtier avec microprocesseur
- 2- Starting relay / relais démarrage
- 3- Starter key / cle de démarrage
- 4- Fuse holder / porte fusible
- 5- Battery / batterie
- 6- Ignition / allumage
- 7- Starter / démarreur
- 8- H.T. coil / bobine

WIRING DIAGRAM (PVL IGNITION, 1ST TYPE)
 SCHEMA CIRCUIT ELECTRIQUE (ALLUMAGE PVL, 1^{ER} TYPE)

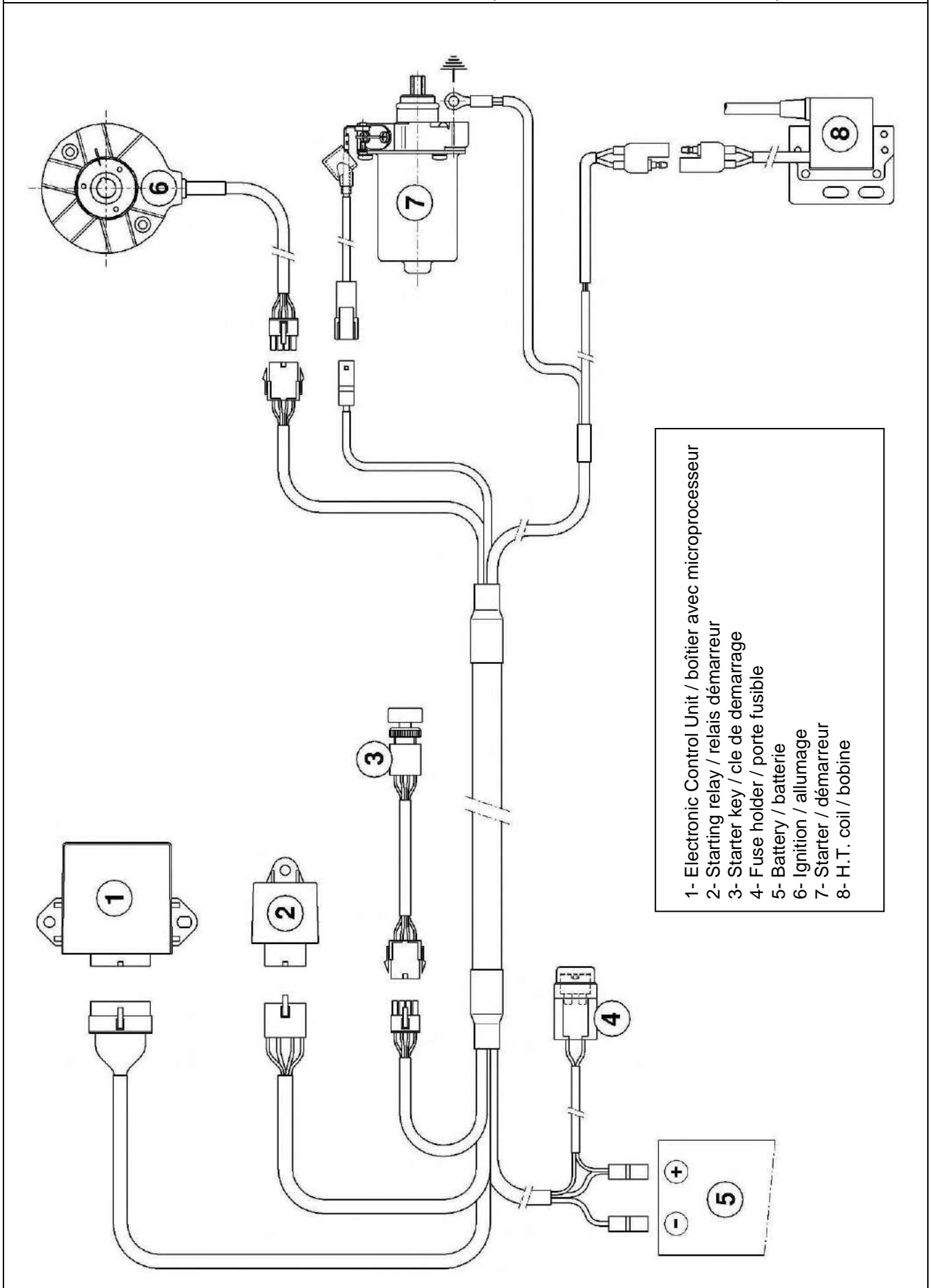

- 1- Electronic Control Unit / boîtier avec microprocesseur
- 2- Starting relay / relais démarrage
- 3- Starter key / cle de démarrage
- 4- Fuse holder / porte fusible
- 5- Battery / batterie
- 6- Ignition / allumage
- 7- Starter / démarrageur
- 8- H.T. coil / bobine

WIRING DIAGRAM (PVL IGNITION, 2nd TYPE)
 SCHEMA CIRCUIT ELECTRIQUE (ALLUMAGE PVL, 2^{ème} TYPE)

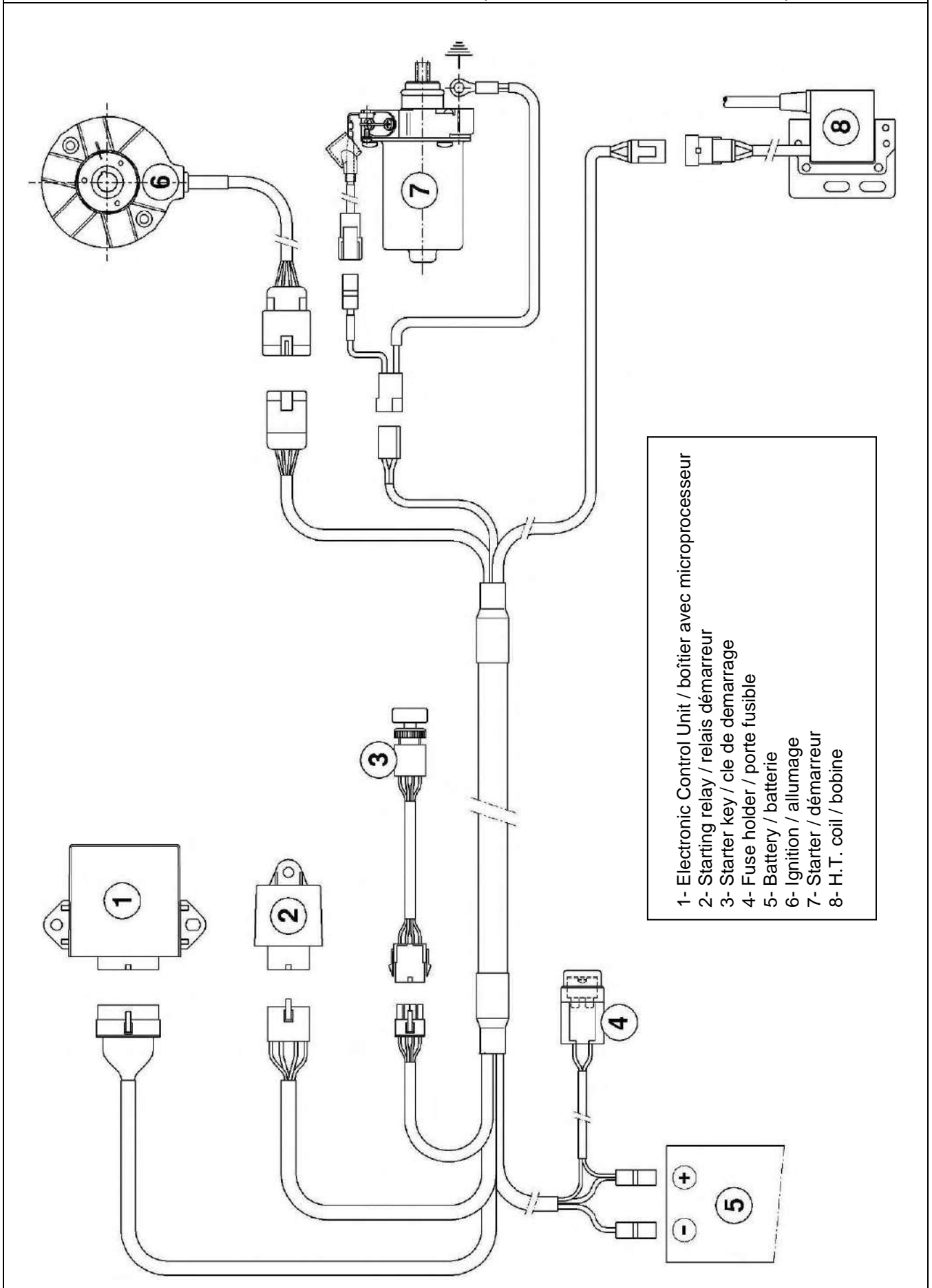

- 1- Electronic Control Unit / boîtier avec microprocesseur
- 2- Starting relay / relais démarrage
- 3- Starter key / cle de démarrage
- 4- Fuse holder / porte fusible
- 5- Battery / batterie
- 6- Ignition / allumage
- 7- Starter / démarrage
- 8- H.T. coil / bobine

SCHEME FOR ADVANCE CONTROL
SCHEMA DE CONTROLE POUR L'AVANCE

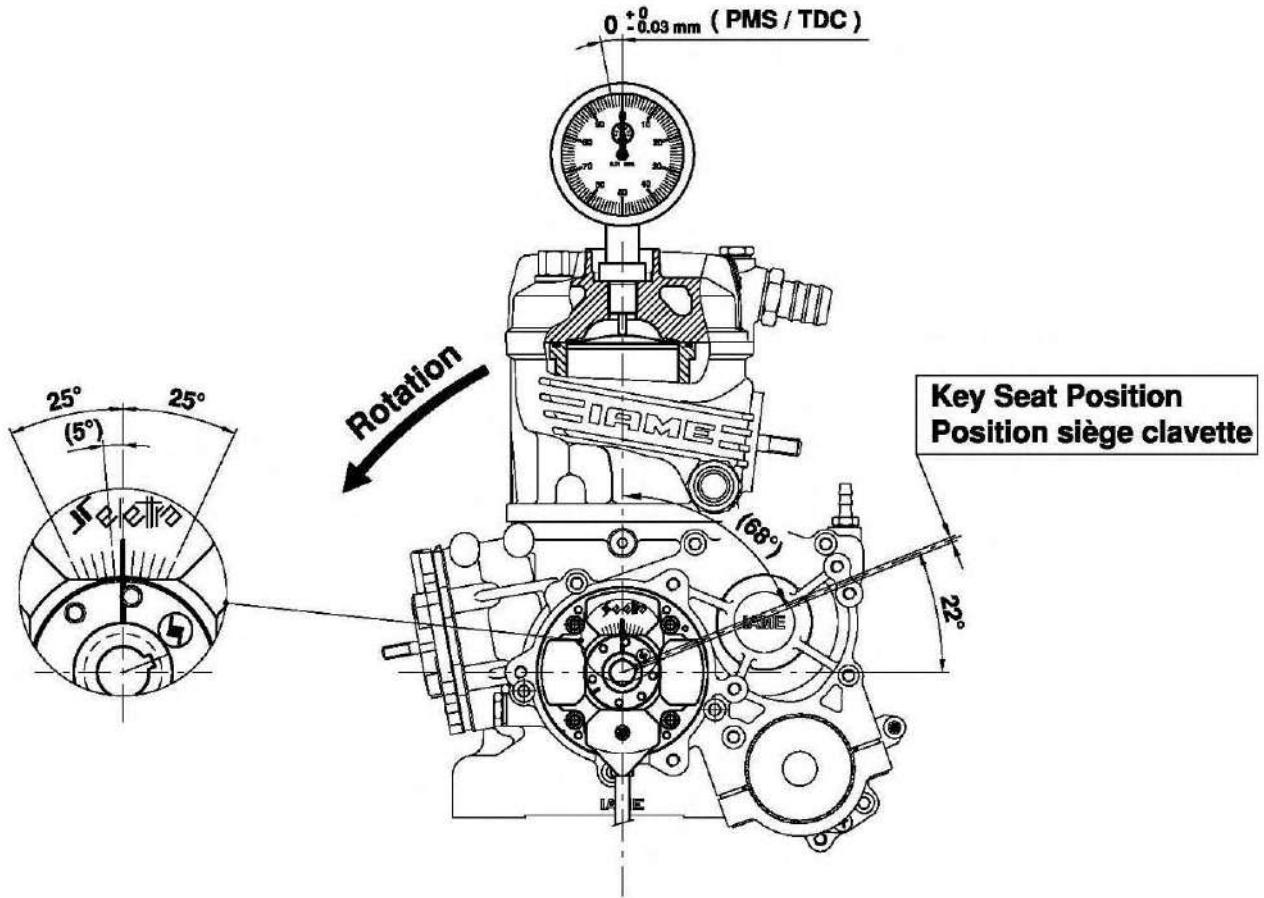

ADVANCE CURVE GRAPHS / GRAPHIQUES DE LA COURBE D'AVANCE

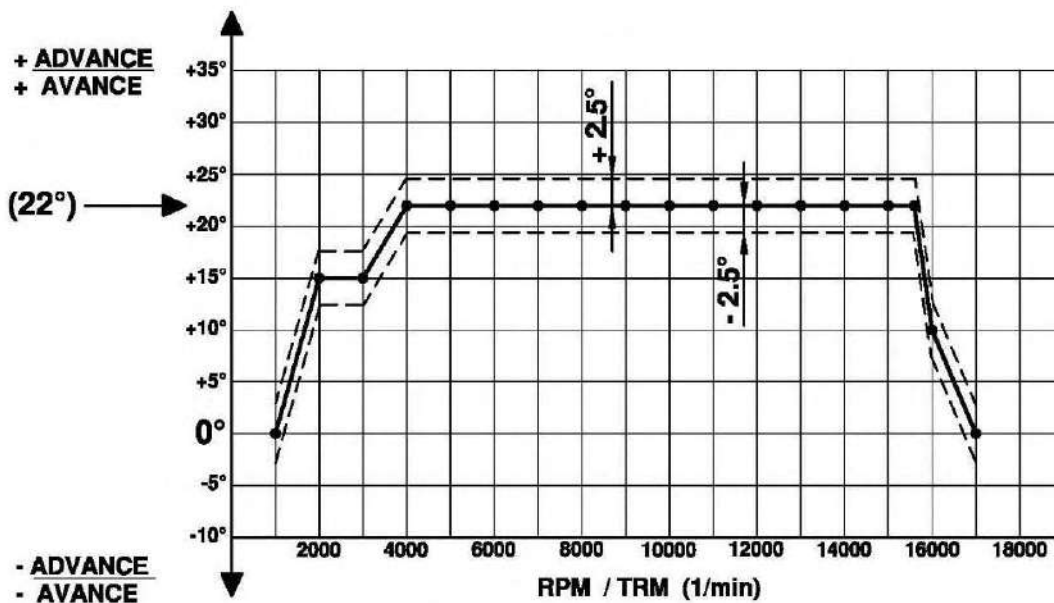

ELECTRONIC BOX MARKING
MARQUAGE DU BOITIER ELECTRONIQUE

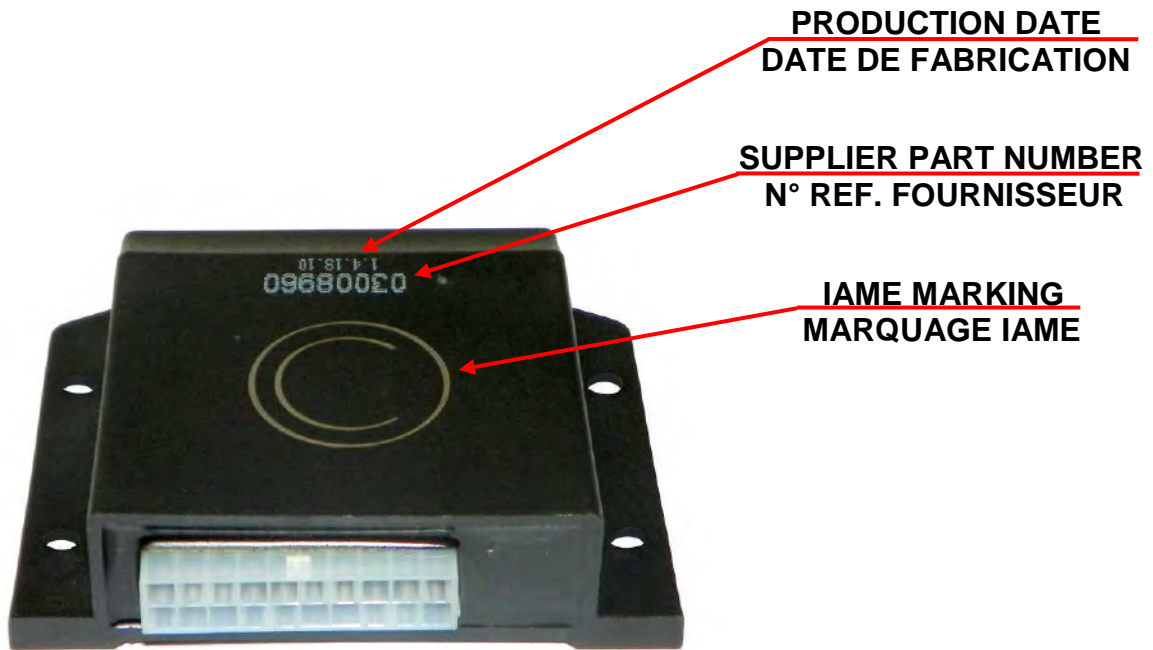

GEAR ALTERNATIVE FIXING
FIXATION ALTERNATIVE DE L' ENGRANAGE

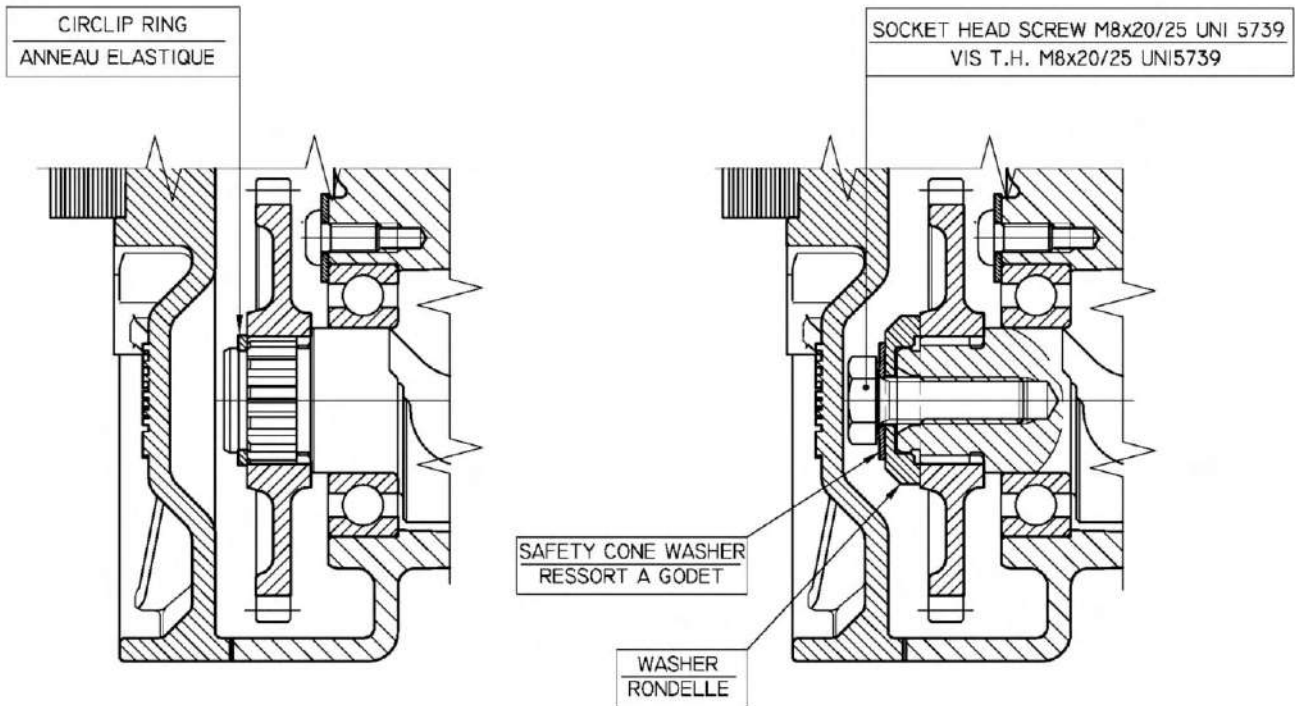

CARBURETTOR COVER ALTERNATIVE
ALTERNATIF COUVERCLE CARBURATEUR

EN PRODUCTION JUSQU' EN
SEPTEMBRE 2007

EN PRODUCTION A PARTIR
D' OCTOBRE 2007

IN PRODUCTION UNTIL
SEPTEMBER 2007

IN PRODUCTION STARTING
FROM OCTOBER 2007



EN PRODUCTION JUSQU' EN
DECEMBRE 2008

EN PRODUCTION A PARTIR
DE JANVIER 2009

IN PRODUCTION UNTIL
DECEMBER 2008

IN PRODUCTION STARTING
FROM JANUARY 2009



DESCRIPTION OF THE CLUTCH - DESCRIPTION DE L' EMBRAYAGE

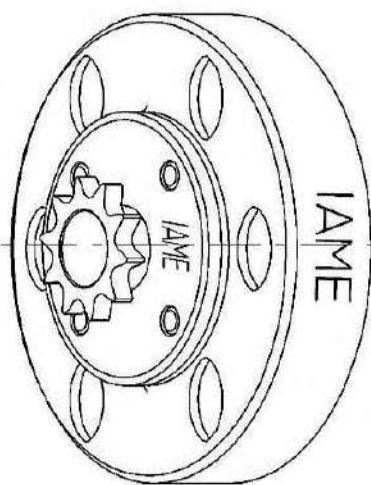

Min. weight 300 g
Poids min. 300 g

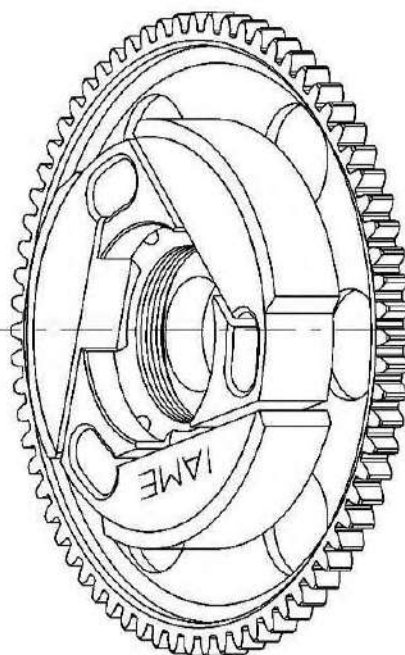

Min. weight 650 g
Poids min. 650 g

RADIATOR DESCRIPTION AND SKETCH OF PARTS
DESCRIPTION DU RADIATEUR ET SCHEMA ILLUSTRANT LES ELEMENTS

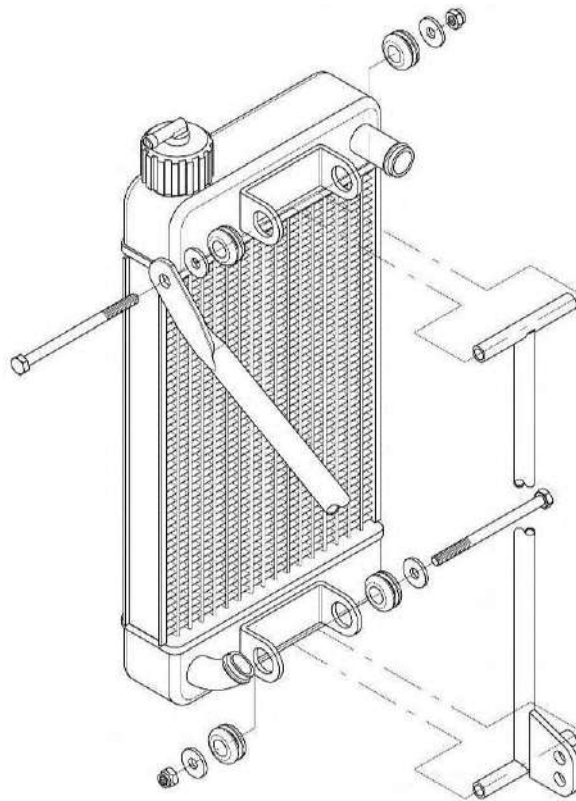
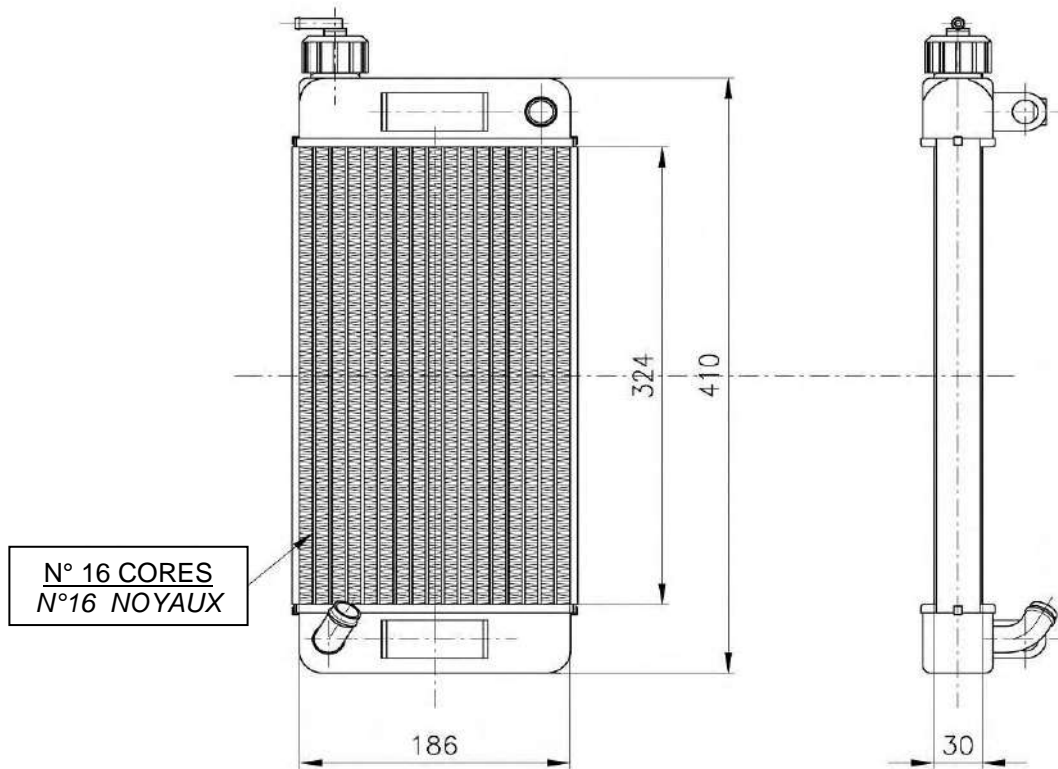

RADIATOR AND ITS SUPPORTS
 RADIATEUR ET SES SUI TIEN

PAINTED AND NOT PAINTED / PEINT ET PAS PEINT



FRONT / AVANT



REAR / ARRIERE



WATER PUMP GROUP
 GROUPE POMPE A' EAU

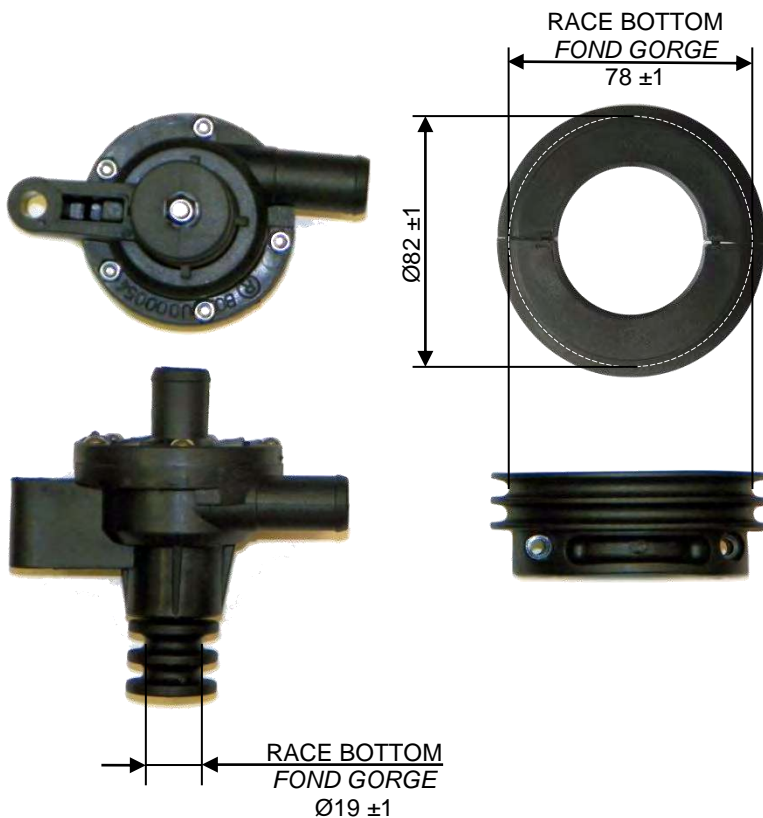

THERMOSTAT



ALTERNATIVE



PISTON IDENTIFICATION MARKING
 MARQUAGE D'IDENTIFICATION PISTON

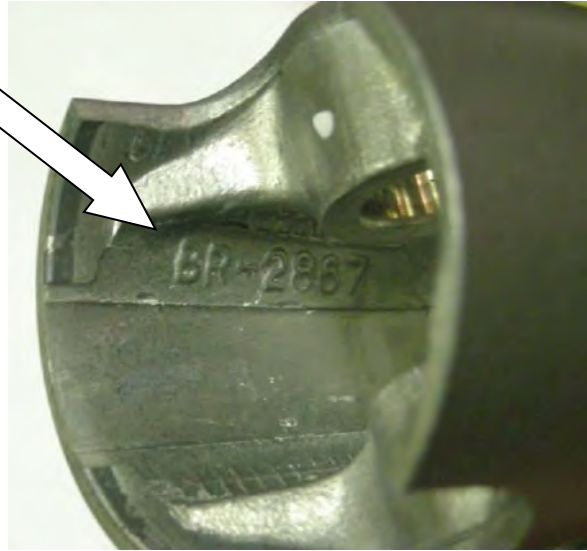
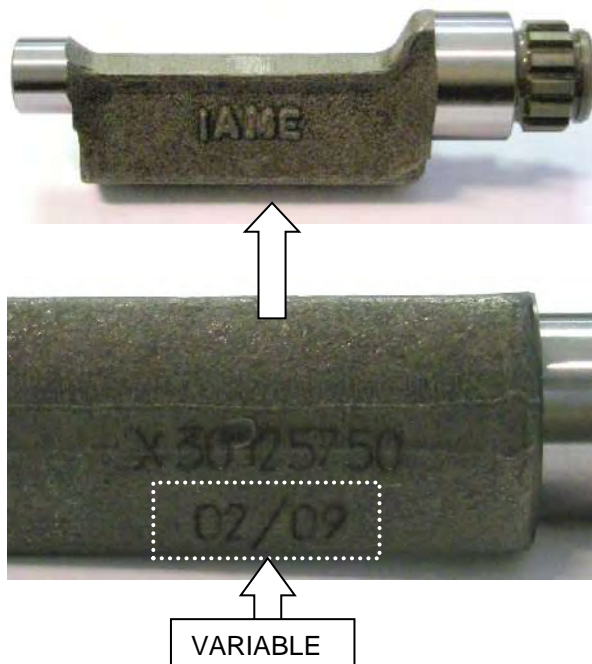
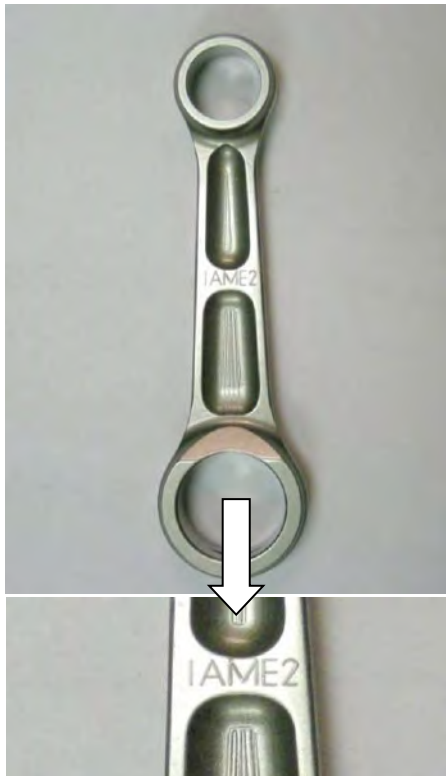

PHOTO IDENTIFICATION CONROD
 MARQUAGE D'IDENTIFICATION BIELLE

IDENTIFICATION BALANCING SHAFT
 MARKING
 MARQUAGE D'IDENTIFICATION ARBRE
 D'EQUILIBRAGE



CRANKSHAFT IDENTIFICATION MARKING
 MARQUAGE D'IDENTIFICATION DU VILEBREQUIN



GEAR COMMAND BALANCING SHAFT
 IDENTIFICATION MARKING
 MARQUAGE D'IDENTIFICATION
 ENGRENAGE ARBRE D'EQUILIBRAGE

STARTER RING IDENTIFICATION MARKING
 MARQUAGE D'IDENTIFICATION DE LA
 COURONNE DE DEMARRAGE

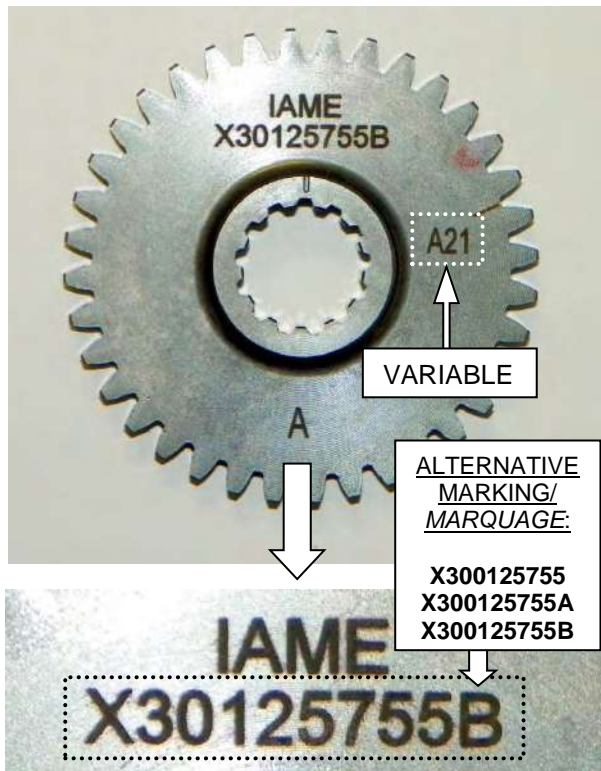

SPROCKET IDENTIFICATION MARKING
 MARQUAGE D'IDENTIFICATION DU
 PIGNON



CLUTCH DRUM IDENTIFICATION MARKING
 MARQUAGE D'IDENTIFICATION DE LA
 CALOTTE



CLUTCH BODY IDENTIFICATION
 MARKING
 MARQUAGE D'IDENTIFICATION CORPS
 DE EMBRAYAGE

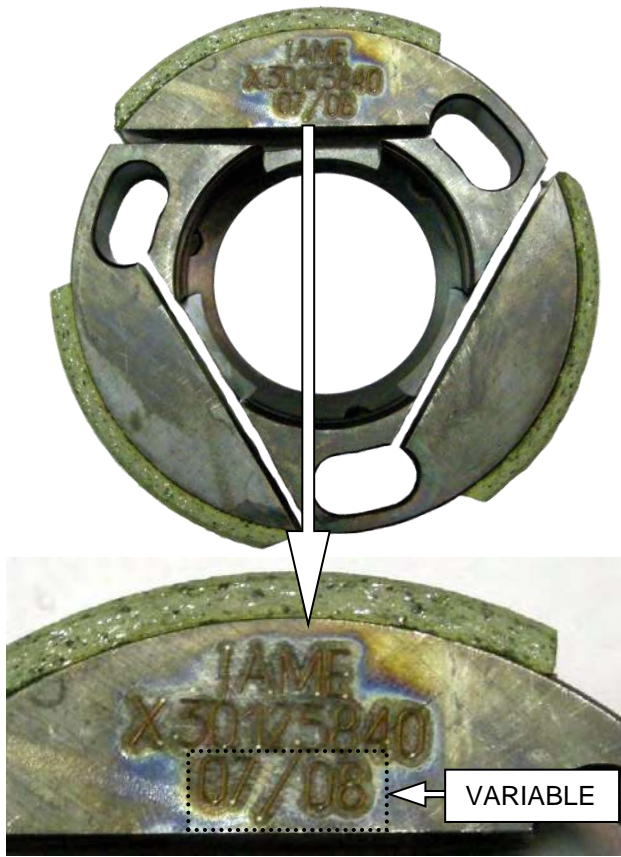

STARTER IDENTIFICATION MARKING
 MARQUAGE D'IDENTIFICATION DU
 MOTEUR DEMARREUR



REED GROUP & PETALS IDENTIFICATION MARKING
 MARQUAGE D'IDENTIFICATION DE LA PYRAMIDE DE CLAPETS & CLAPETS

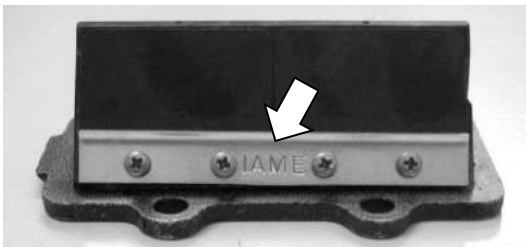
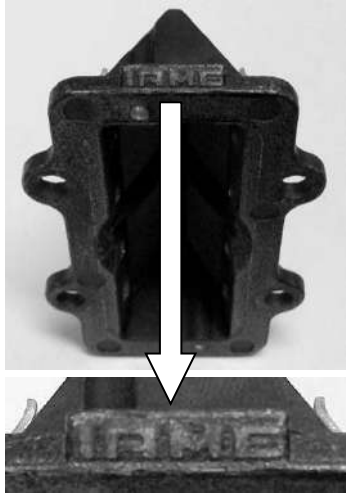

VETRONITE

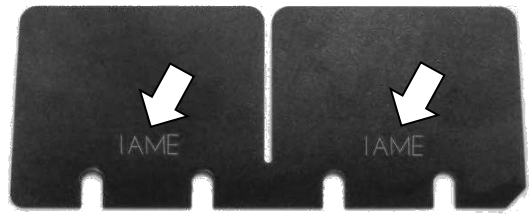

CARBON FIBER

FRONT SIDE

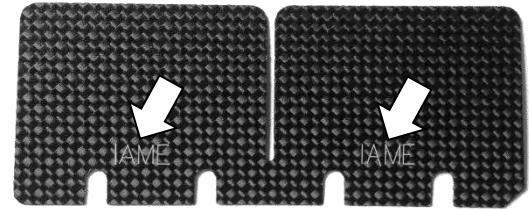

REAR SIDE

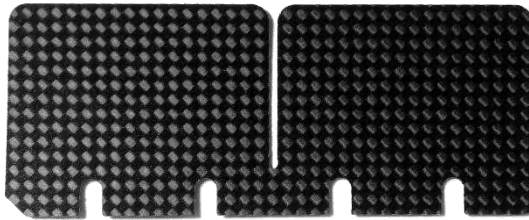
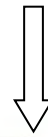

PHOTO IDENTIFICATION
 CARBURETOR INLET CONVEYOR
 MARQUAGE D'IDENTIFICATION DU
 COLLECTEUR D'ASPIRATION



EXHAUST SILENCER IDENTIFICATION
 MARKING
 MARQUAGE D'IDENTIFICATION
 ECHAPPEMENT



HEADER EXHAUST IDENTIFICATION MARKING
MARQUAGE DU COUDE D'ÉCHAPPEMENT



STATOR IDENTIFICATION MARKING
MARQUAGE D'IDENTIFICATION DU STATOR

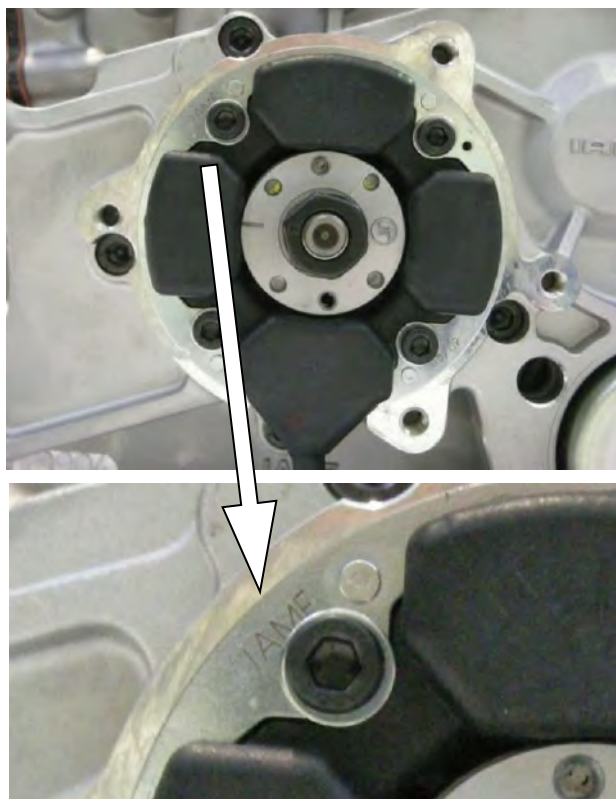

CLUTCH COVER AND H.T. COIL IDENTIFICATION MARKING
MARQUAGE DU COUVERCLE D'EMBRAYAGE ET DE LA BOBINE



BENDIX COVER IDENTIFICATION MARKING
MARQUAGE D'IDENTIFICATION DU COUVERCLE
DU CONTRE-ARBRE DE DEMARRAGE

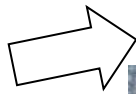
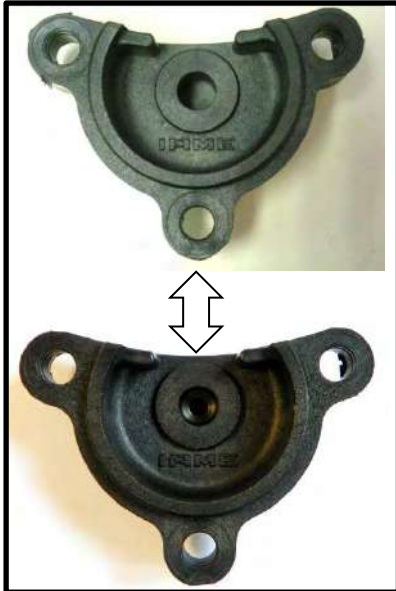

ALTERNATIVE



DESCRIPTION OF THE CLUTCH 2013 - DESCRIPTION DE L' EMBRAYAGE 2013

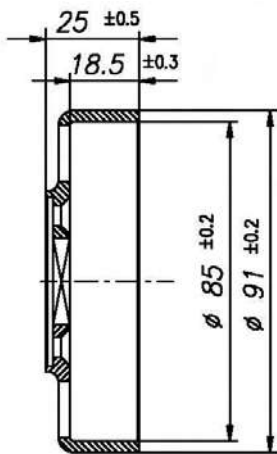
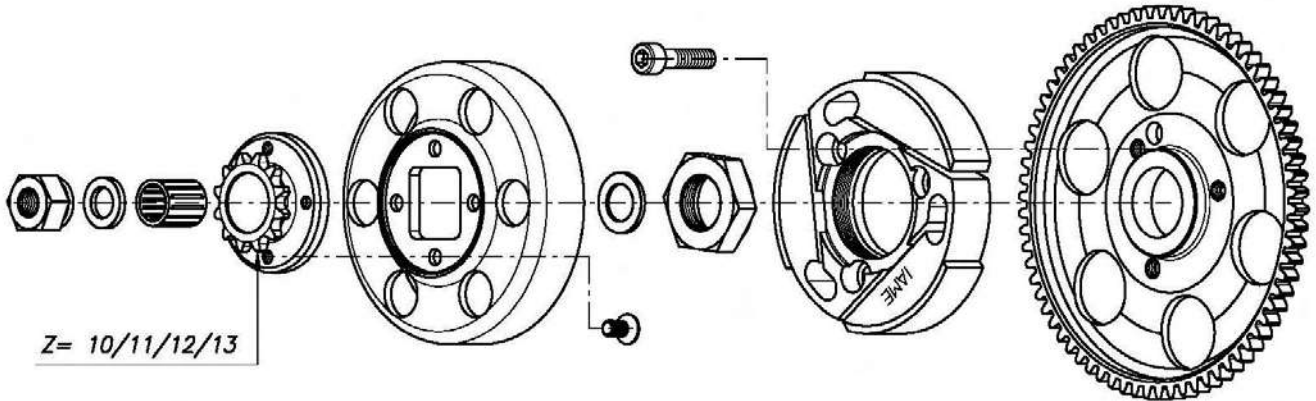

Min. weight 225 g
Poids min. 225 g

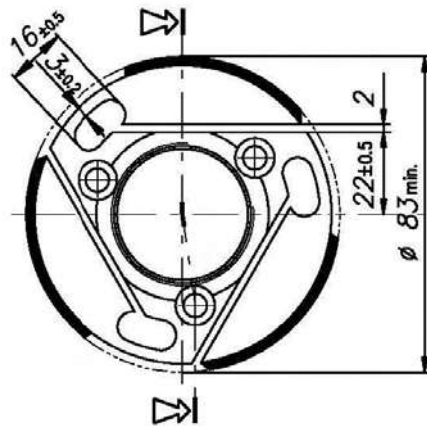

Min. weight 375 g
Poids min. 375 g

CLUTCH BODY 2013 IDENTIFICATION MARKING
MARQUAGE D'IDENTIFICATION CORPS DE EMBRAYAGE 2013

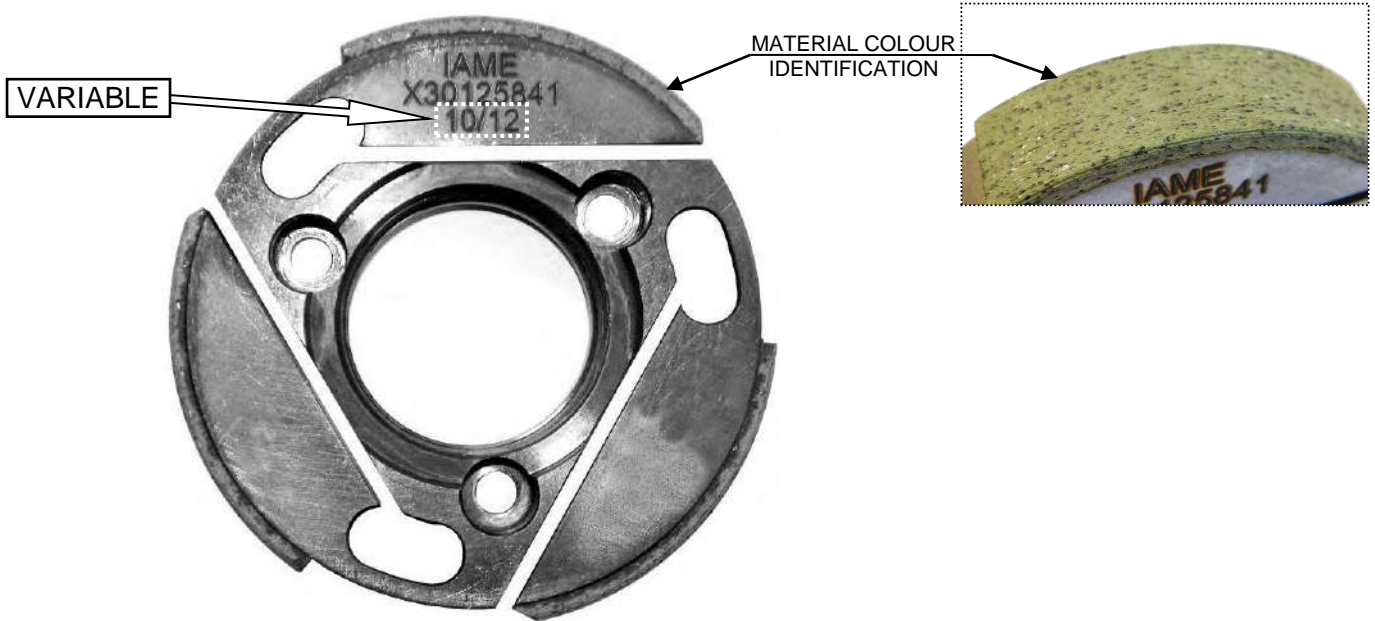

DESCRIPTION OF THE CLUTCH 2013 - DESCRIPTION DE L' EMBRAYAGE 2013

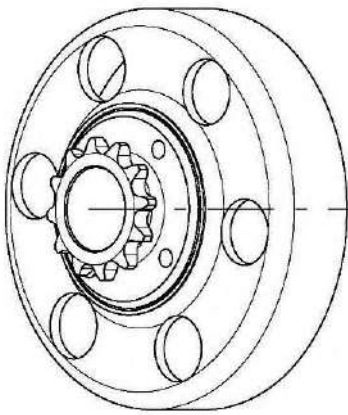

Min. weight 300 g
Poids min. 300 g

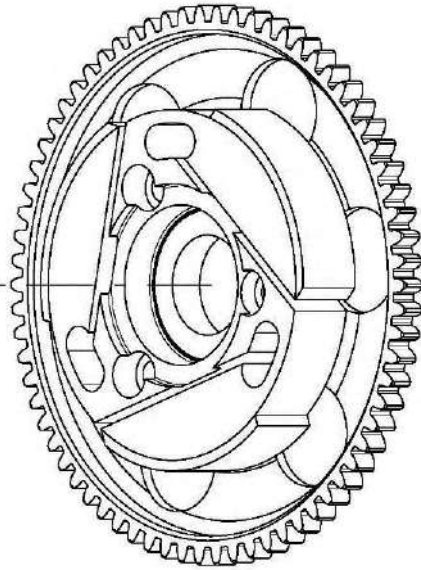

Min. weight 680 g
Poids min. 680 g

STARTER RING 2013 IDENTIFICATION MARKING
MARQUAGE D'IDENTIFICATION DE LA COURONNE DE DEMARRAGE 2013

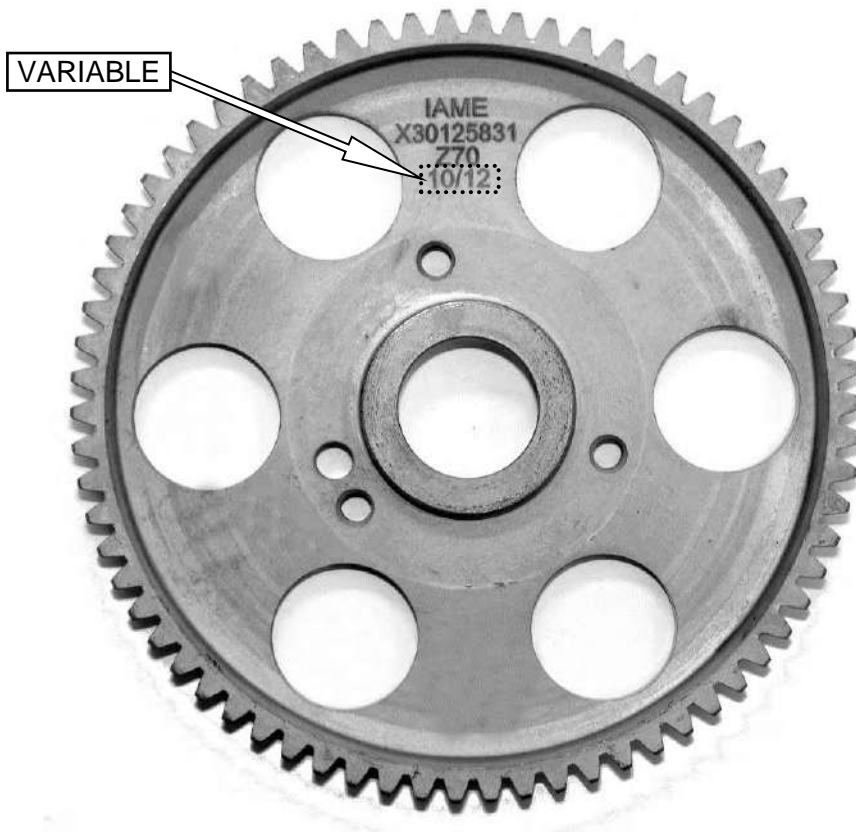

WIRING DIAGRAM (SELETTRA DIGITAL "K" IGNITION 2013)
 SCHEMA CIRCUIT ELECTRIQUE (ALLUMAGE SELETTRA DIGITAL "K" 2013)

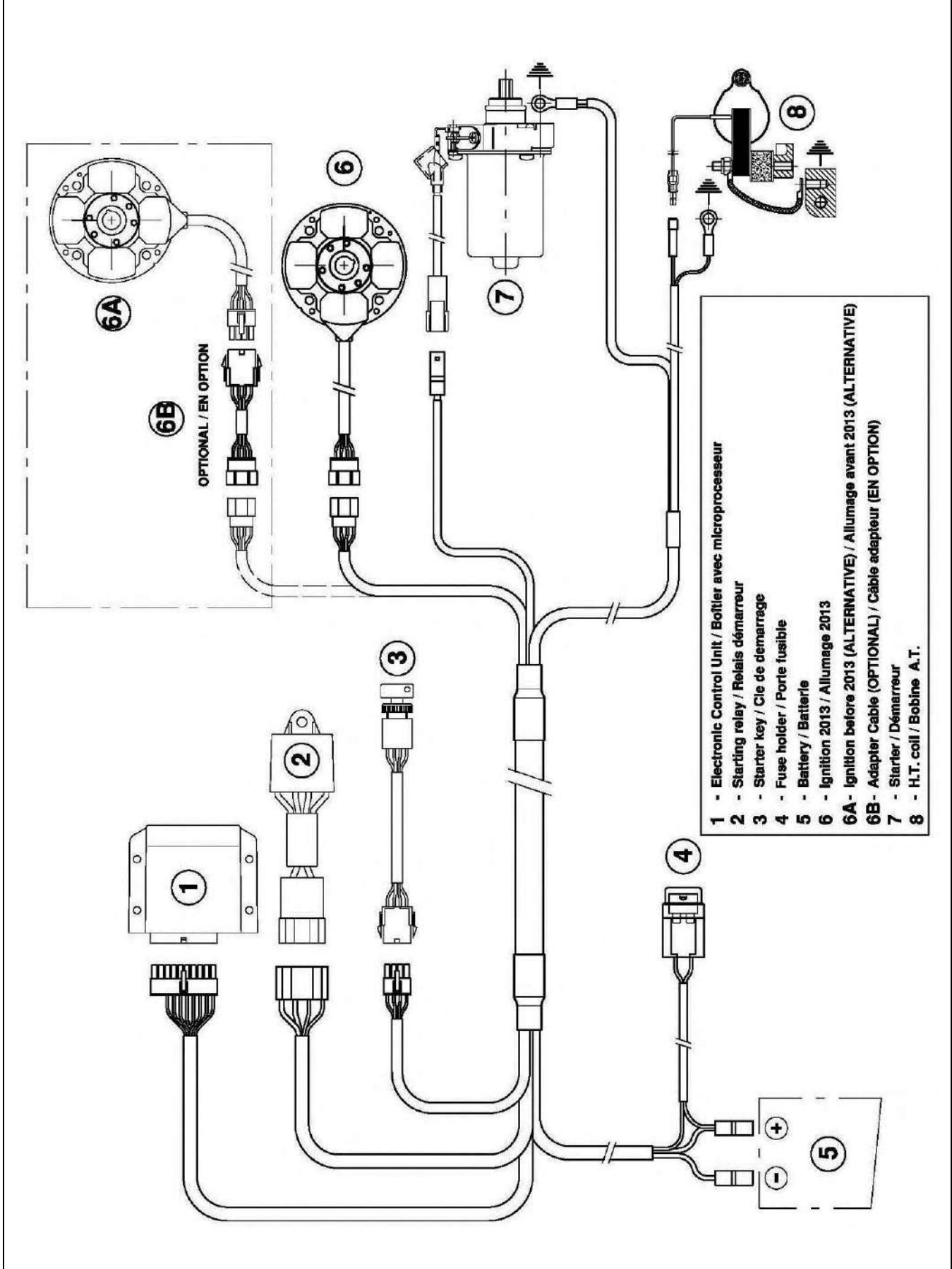

FROM 2014 ON - A PARTIR DE 2014

STICKER APPLICATION AREA - *ESPACE POUR L'APPLICATION DE ADHÉSIFS*



ALTERNATIVE AREA



HEADER EXHAUST DIMENSIONS
CODE D'ÉCHAPPEMENT TAILLE

CYLINDER CROSS SECTION VIEW
VUE EN SECTION DU CYLINDRE

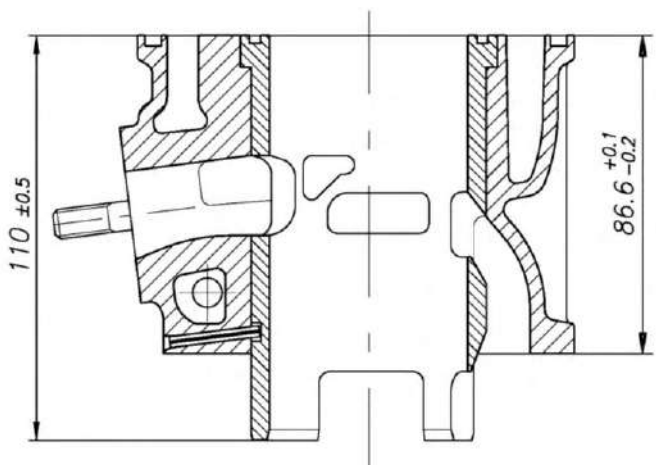
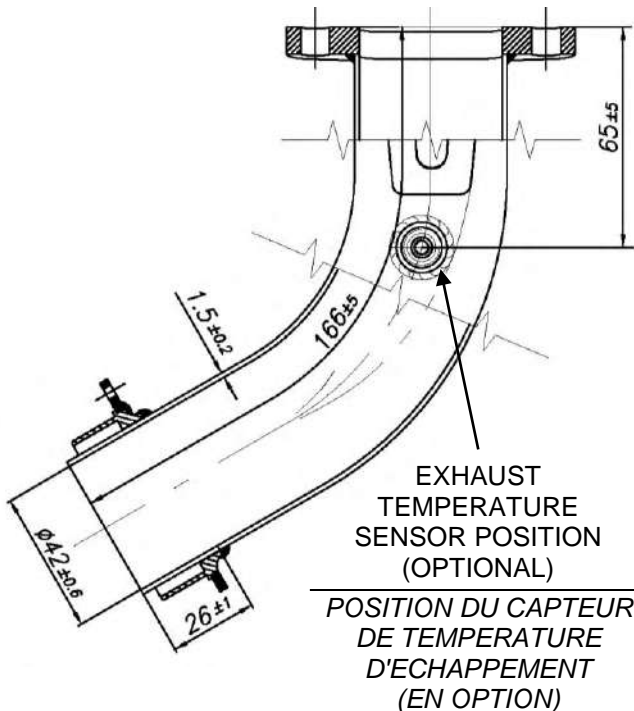

CYLINDER IDENTIFICATION MARKING
MARQUAGE D'IDENTIFICATION DU CYLINDRE

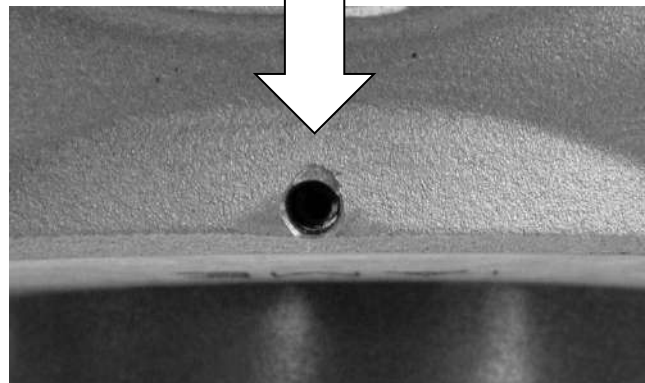
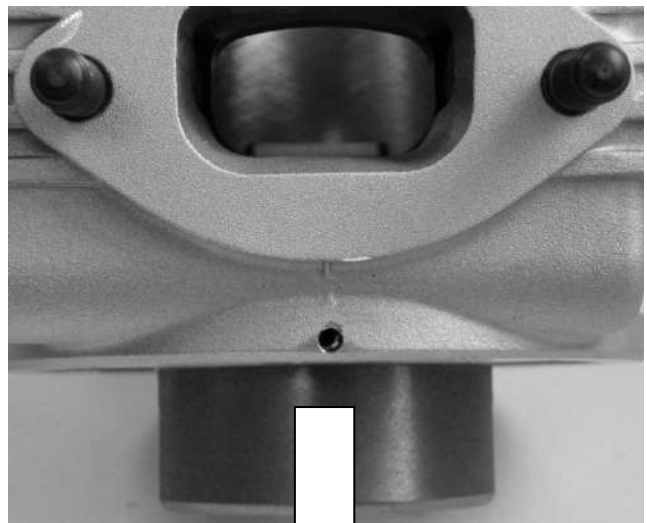
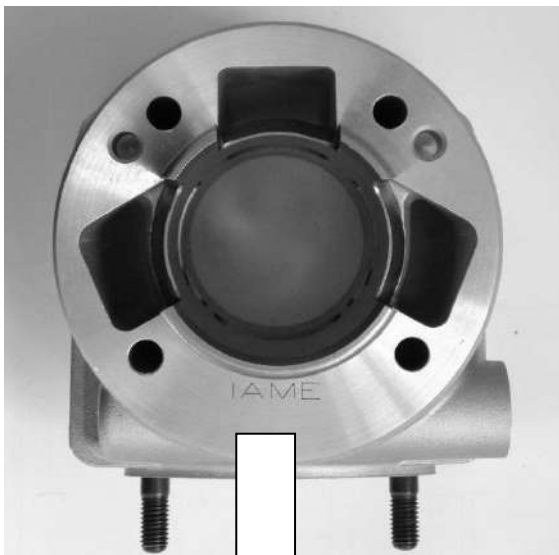
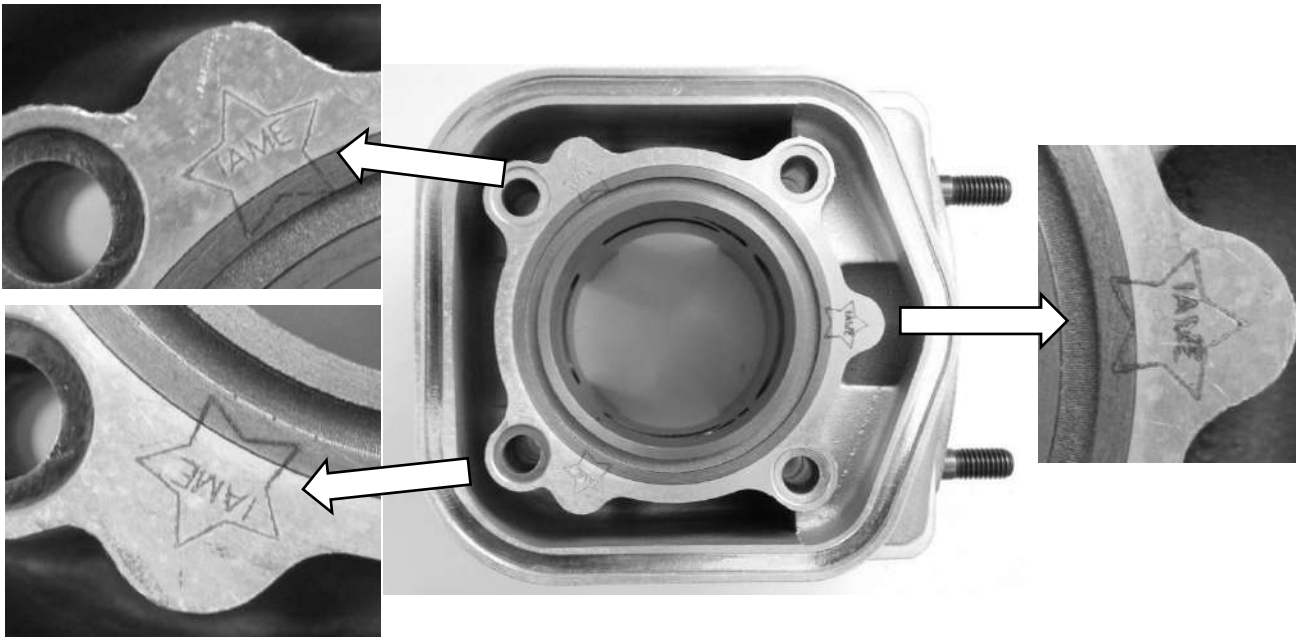
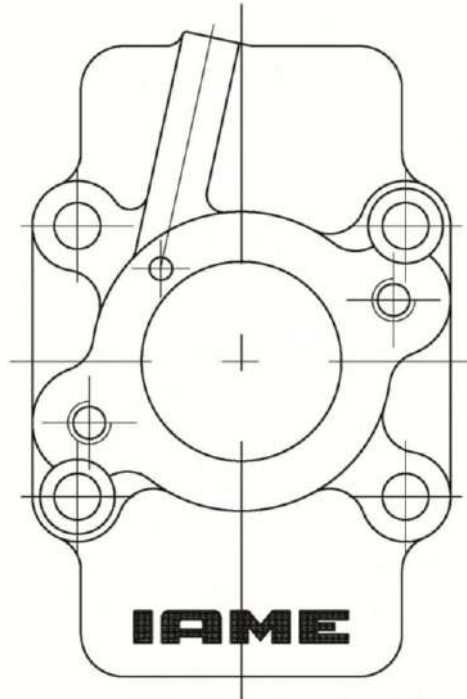

PHOTO IDENTIFICATION CARBURETTOR INLET CONVEYOR
MARQUAGE D'IDENTIFICATION DU COLLECTEUR D'ASPIRATION

Old version - while stocks last
Vieille version - jusqu'à épuisement des stocks



IN ALTERNATIVE

New version
Nouvelle version

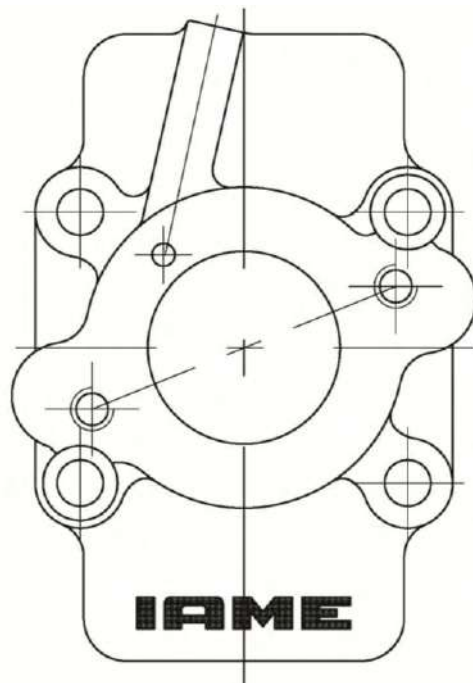

DESCRIPTION OF THE CLUTCH 2015 - DESCRIPTION DE L' EMBRAYAGE 2015

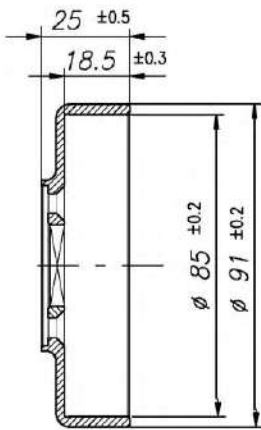
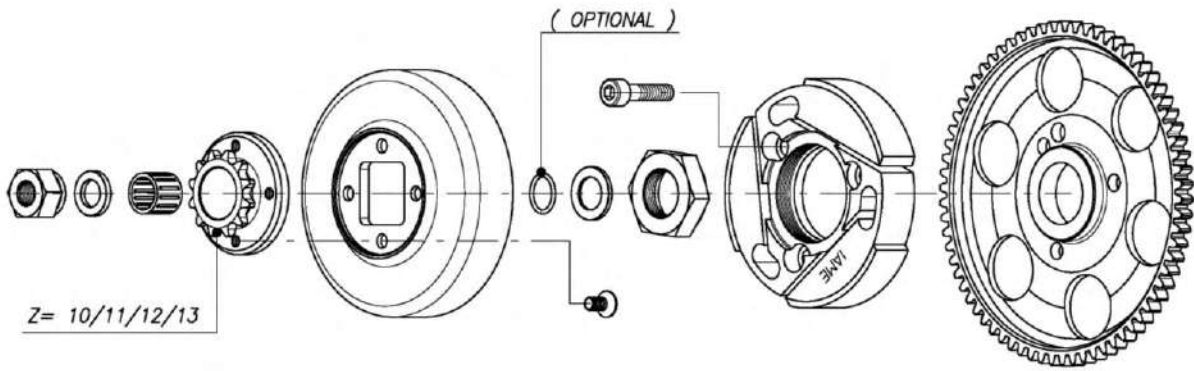

Min. weight 225 g
Poids min. 225g

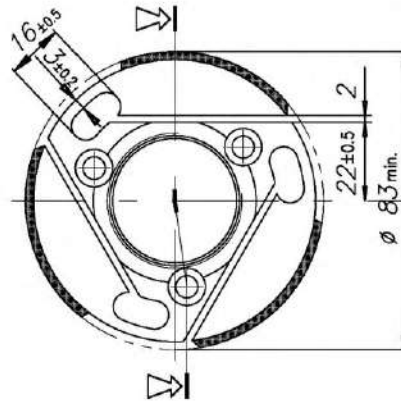

Min. weight 375 g
Poids min. 375g

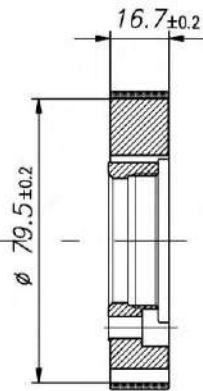

CLUTCH DRUM 2015 IDENTIFICATION MARKING
MARQUAGE D'IDENTIFICATION DE LA CALOTTE 2015

WEIGHT MIN. OF THE CLUTCH 2015
POIDS MIN. DE L' EMBRAYAGE 2015

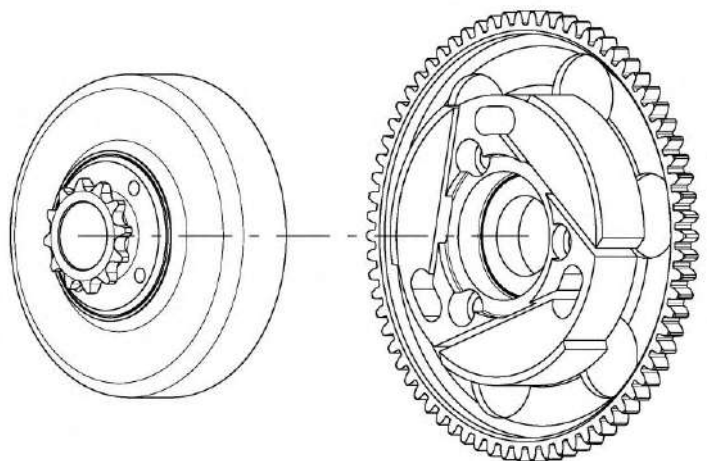

Min. weight 300 g
Poids min. 300 g

Min. weight 680 g
Poids min. 680 g

ALTERNATIVE PUSH BUTTONS – START & STOP
BOUTONS “START & STOP” DU DEMARREUR ALTERNATIVE

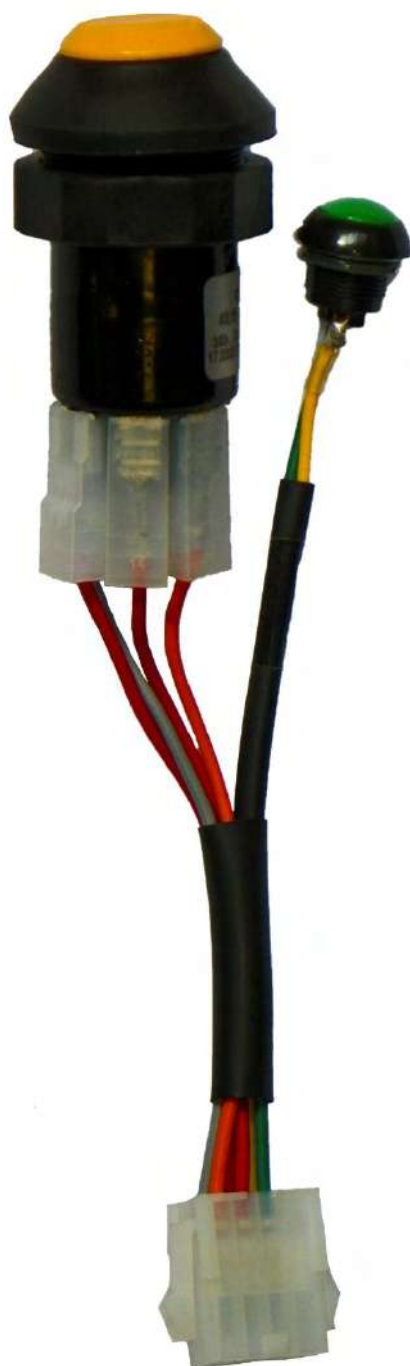
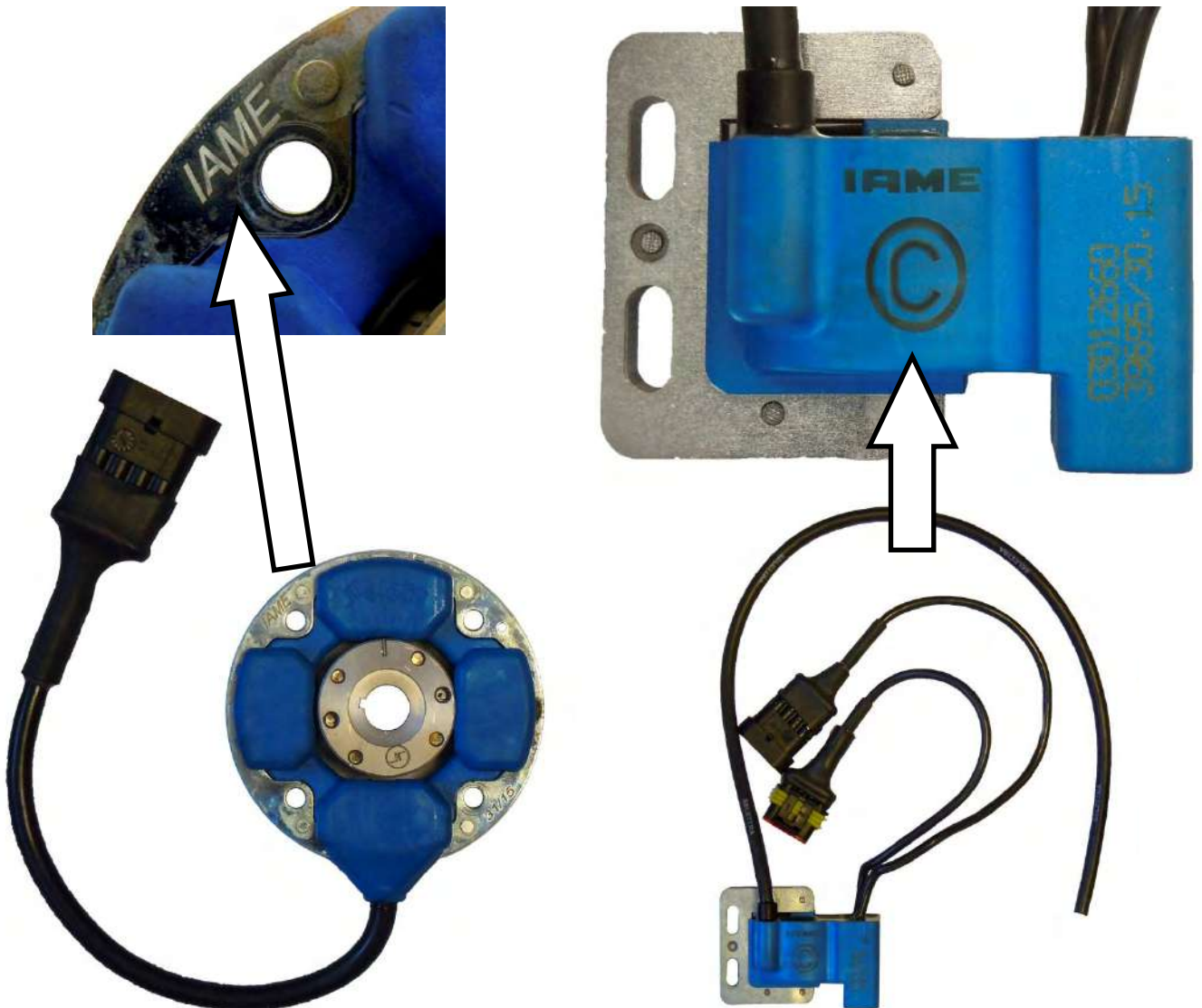

PHOTO COMPLETE ALTERNATIVE WIRING LOOM
PHOTO DU CABLAGE ELECTRONIQUE COMPLET



PHOTO OF SELETTRA ALTERNATIVE DIGITAL "S" IGNITION, WITH IAME MARKING
PHOTO DU SELETTRA DIGITAL "S" ALLUMAGE, AVEC MARQUAGE IAME



WIRING DIAGRAM (SELETTRA DIGITAL "S" IGNITION)
 SCHEMA CIRCUIT ELECTRIQUE (ALLUMAGE SELETTRA DIGITAL "S")

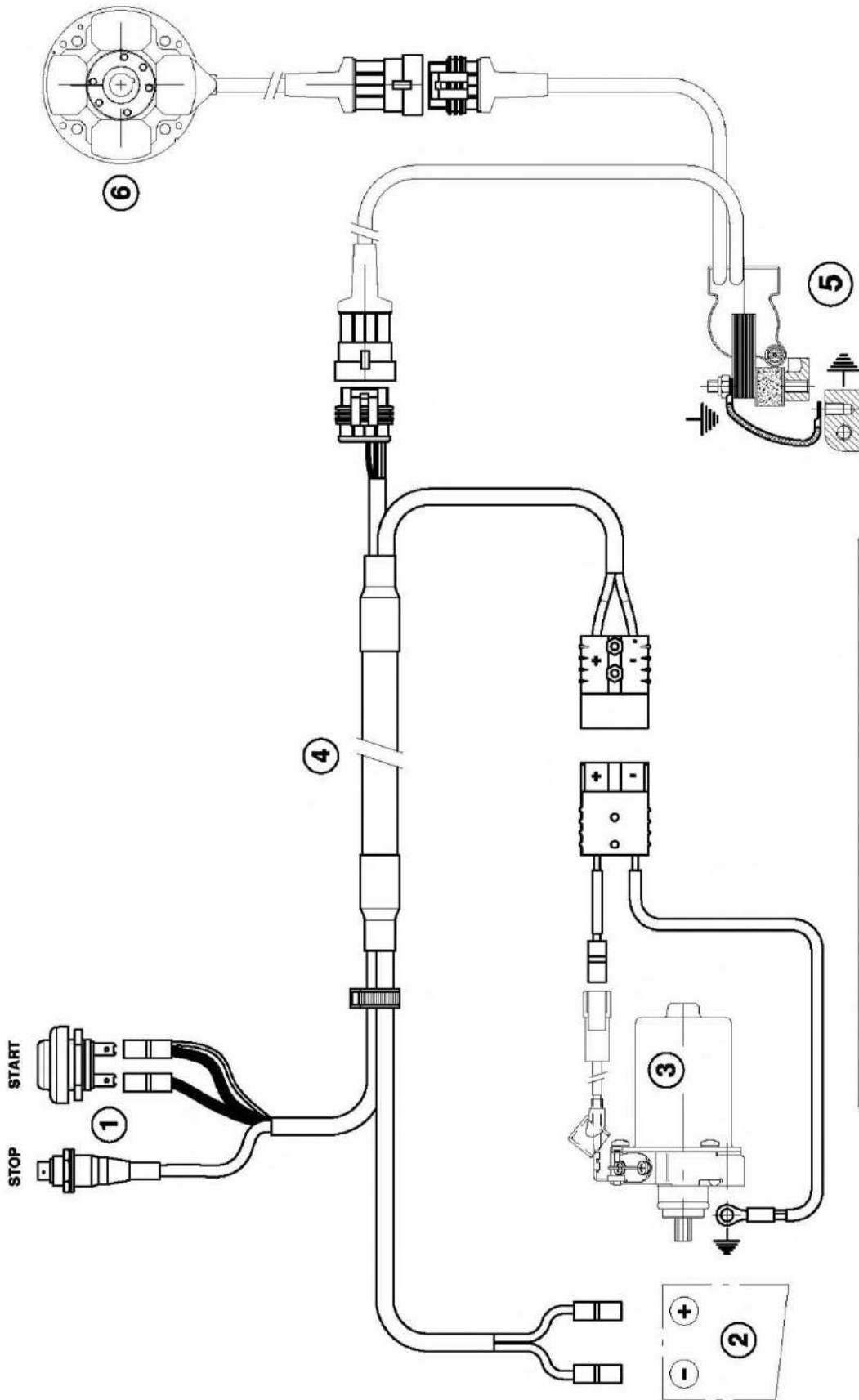

- 1 - Push buttons Start & Stop / Bouton poussoir du démarreur
- 2 - Battery / Batterie
- 3 - Starter / Démarreur
- 4 - Wiring cable / Cablage électrique
- 5 - H.T. coil and Electronic Control Unit / Bobine A.T. et boîtier avec microprocesseur
- 6 - Ignition / Allumage

PHOTO IDENTIFICATION REED GROUP
PHOTO IDENTIFICATION PYRAMIDE DE CLAPETS

CURRENT VERSION
ACTUAL VERSION

ALTERNATIVE VERSION
VERSION ALTERNATIVE

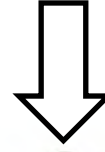
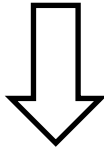

ACTUAL PISTON
PISTON COURANT



VARIABLE

ALTERNATIVE PISTON
PISTON ALTERNATIVE

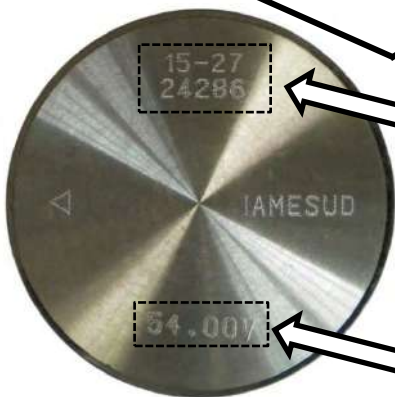

VARIABLE

VARIABLE